

POW-R-QUIK

Starter Part Number: 6-HS-116 RHX

Hydraulic Starter Specification	
Engine Application	Various Gas & Diesel Engines
Hydraulic Oil, Supply Pressure	3000 psi (207 bar) Maximum
Hydraulic Oil, Flow Required @3000 psi	14-18 GPM (53-68 LPM)
Hydraulic Oil, Specification	Normal operating viscosity range: 80-1000 SUS (16-220 cSt) Maximum startup viscosity should not exceed 4000 SUS (864 cSt)
Max starter torque output at 3000psi (207 BAR)	52.2 ft-lbs (70.77 Nm)
Operating Temperatures	-40° F to 180° F (-40°C to 82°C)
Flange Characteristics	Engine Dependent
Pinion Characteristics	Engine Dependent
Weight	28 lbs (12.7 kg)

$$\text{Pinion speed} = \text{engine speed} * \frac{\text{ring gear tooth count}}{\text{pinion tooth count}}$$

$$\text{Engine torque} = \text{starter torque} * \frac{\text{ring gear tooth count}}{\text{pinion tooth count}}$$

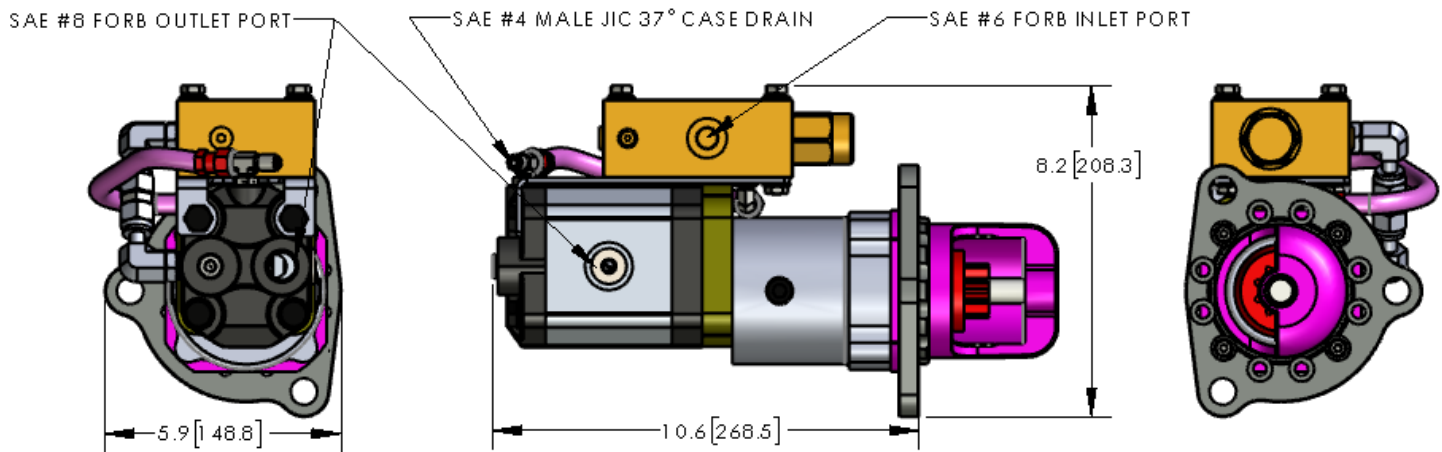
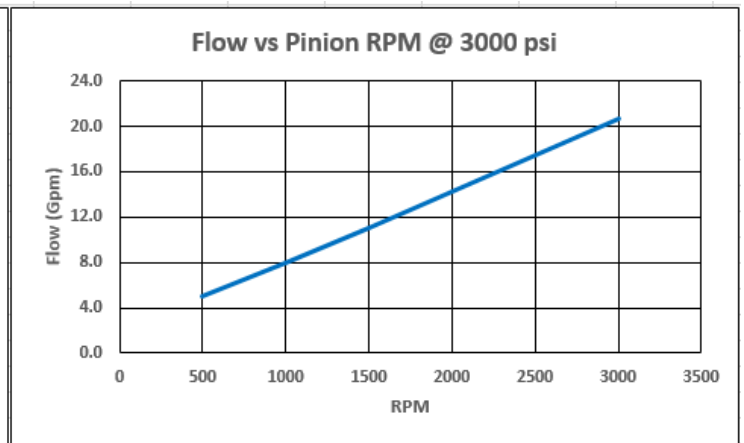
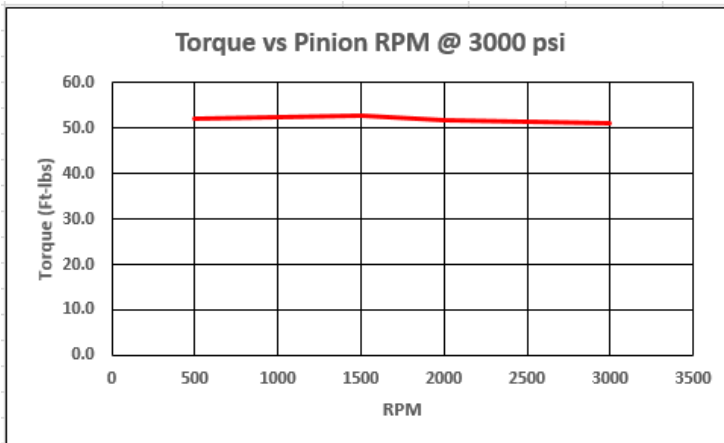

Units: in [mm]

Note: Case Drain must be vented to the tank or return line