



**Performance
Reliability
Quality**

HS Series

The best gets better...

**Hydraulic
Starters**

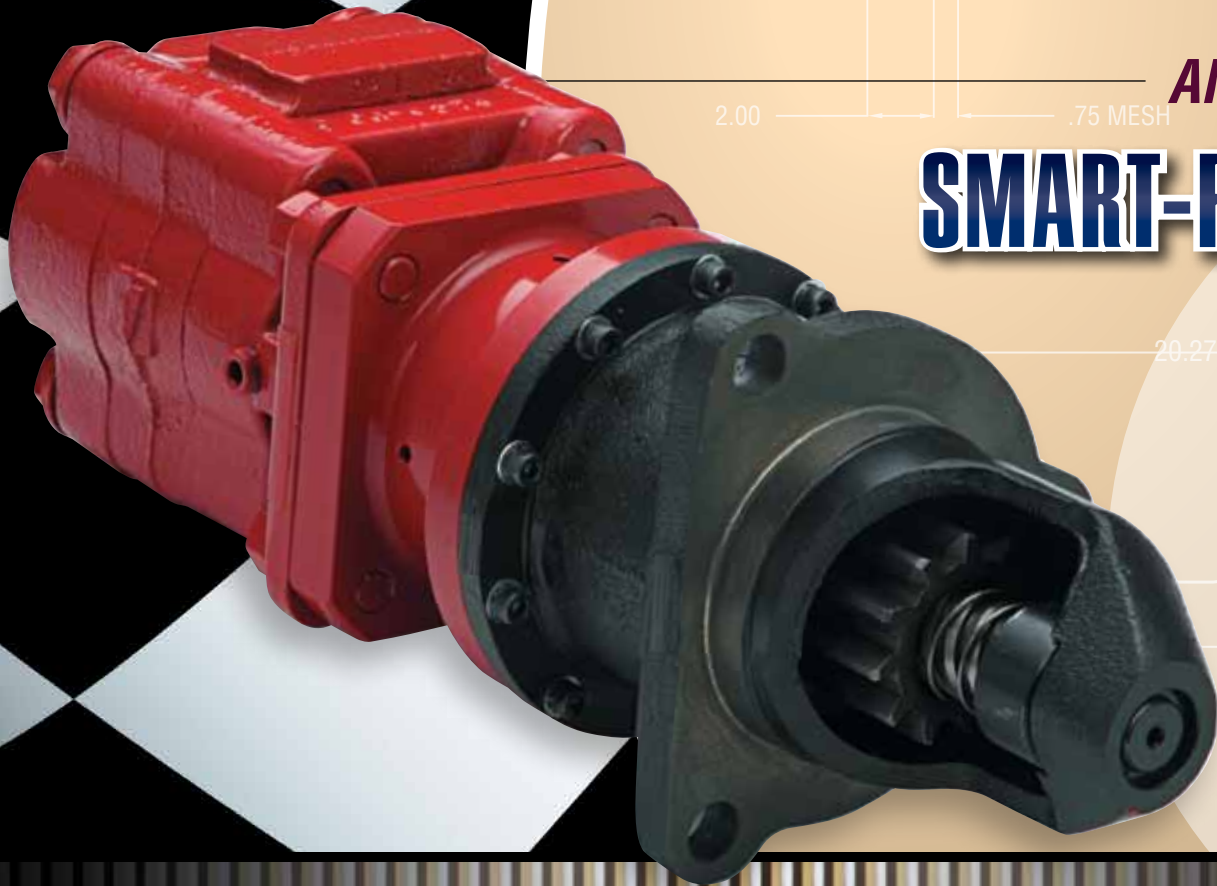

AND

SMART-R-VALVE™



**The Soft
Engagement
Valve**

Patent pending



Pow-R-Quik



Pow-R-Quik

HS Series 22 & 36 Starters & Gear Motor Hydraulic Starters

HS-22 & HS-36

Friction Clutch Inertia Drives

These starters are adapted from PRQ's 23/24 and 60/61 series air starters. They can be purchased with or without motors. Both use friction clutch starter drives.

HS-360

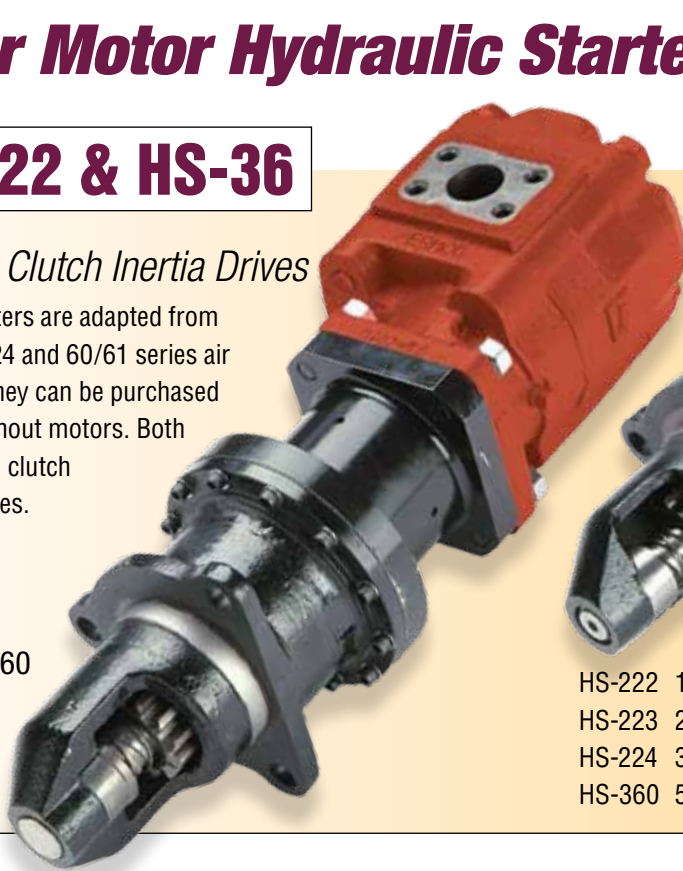

HS-223

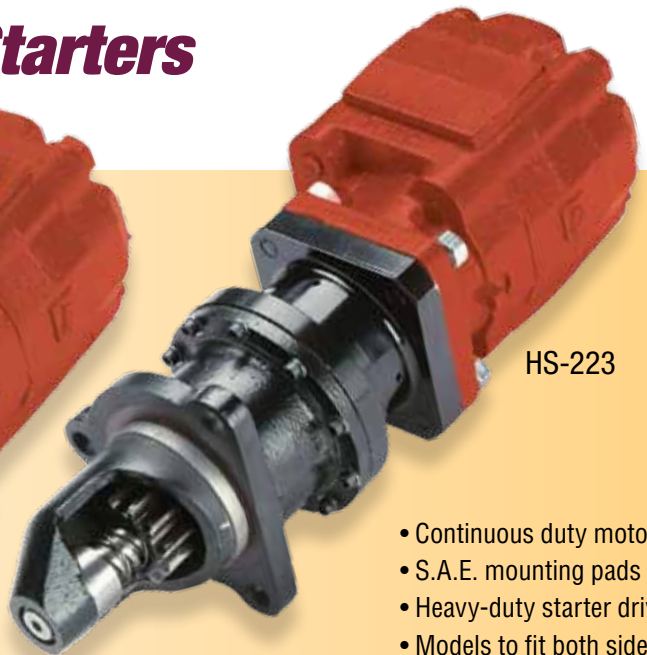

- HS-222 1 cu. in. (16.4 cc)
- HS-223 2 cu. in. (32.8 cc)
- HS-224 3 cu. in. (49.2 cc)
- HS-360 5.15 cu. in. (84.3 cc)

- Continuous duty motors
- S.A.E. mounting pads
- Heavy-duty starter drives
- Models to fit both sides of multi-pad engines
- Can be purchased less motor
- Side and rear ports

Factory Installed Smart-R-Valve™!



HS starters are now available with a Smart-R-Valve™ installed and tested at the factory. How easy is that?

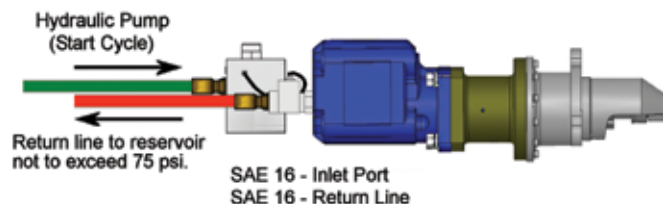

All SAE ports are Straight Threaded O-ring Boss (ORB)

Hydraulic Starting Systems

Designed for the hydraulic fracturing market

Smart-R-Valve™ ...

**The best hydraulic starting system
in the “Fracking World”**



SMART-R-VALVE™

Say Goodbye to Pressure Spikes

Adjustments: None required

Flow Rating: 50-80 GPM

Temperature Range:
-40° to 180°

**Consult factory for extreme
ambient temperature
applications.**

PreEngages the pinion to ring gear

NO MORE broken ring gears

NO MORE broken drives

NO MORE broken nose cones

NO MORE downtime

**Consult factory for
system compatibility**



Broken nose cone and drive on the first cycle.

Unbelievable Results!



The Smart-R-Valve™ Advantage

“We set up our test rig so we could break the starter drive and the nose cone of our test starter with just one cycle. With the addition of the Smart-R-Valve™ to the rig with the same pressures and flow we have gone thousands of cycles and the pinion and the drive looks like new.”

– Ed Zaleski, Test Engineer

HS Series

Hydraulic Starters

The next generation hydraulic starter with integrated **soft start** (smart R valve) in the back cover is available (released year: 2013)

For more information visit (<https://powrquik.com/hydraulic-starters/>)

1. [HSV-223, HSV-224](#)
2. [HSCV-360](#)

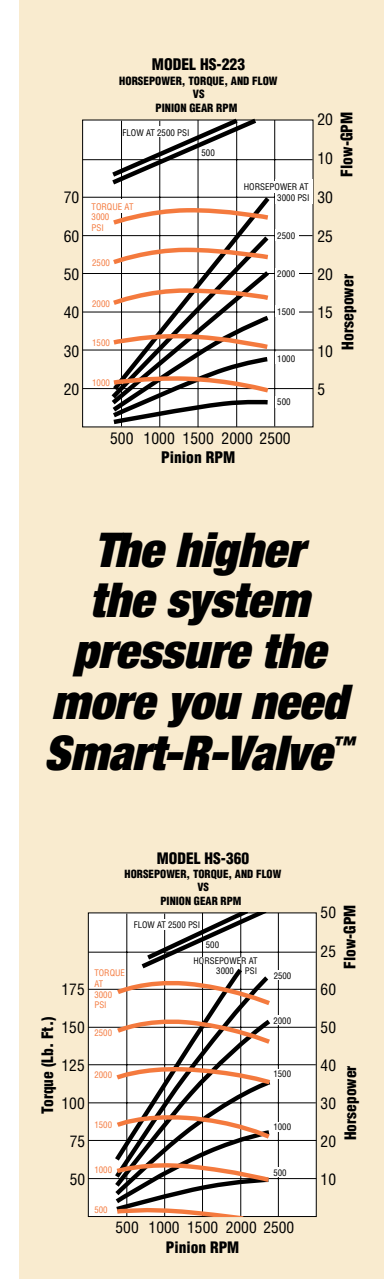
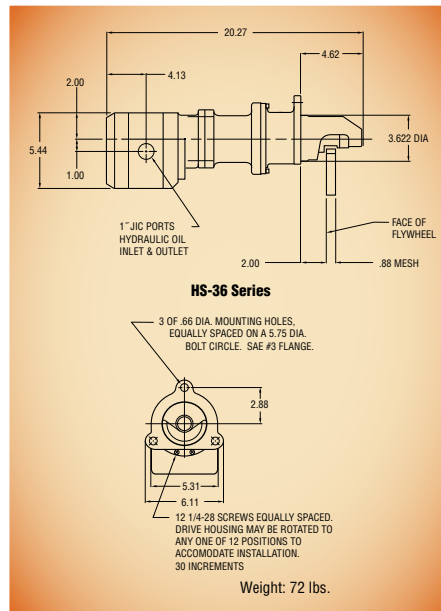
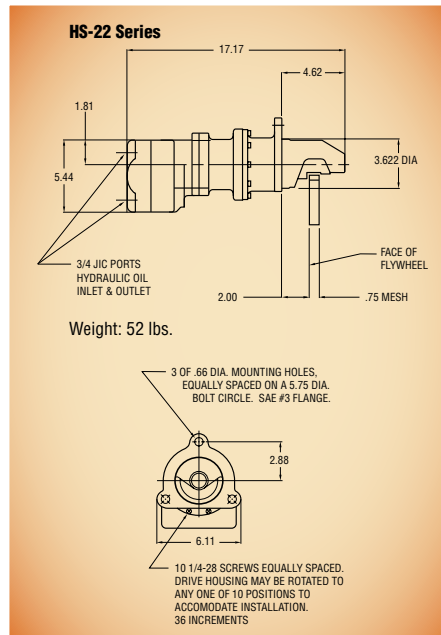

The higher the system pressure the more you need Smart-R-Valve™

POW-R-QUIK
ENGINE STARTING SYSTEMS

4540 West 160th Street, Cleveland, Ohio 44135
(216) 404 – 7112
sales@powrquik.com

MARADYNE Corporation
MANUFACTURING INNOVATION