

Starter Part Number: 6-HS-114 RHX

Hydraulic Starter Specification	
Engine Application	Various Gas & Diesel Engines
Hydraulic Oil, Supply Pressure	3000 psi (207 bar) Maximum
Hydraulic Oil, Flow @3000 psi	See Chart Below (Do not exceed 13 gpm [79.5 lpm])
Max starter torque output at 3000psi (207 BAR)	30.3 ft-lbs (41.1 Nm)
Hydraulic Oil, Specification	Normal operating viscosity range: 80-1000 SUS (16-220 cSt) Maximum startup viscosity should not exceed 4000 SUS (864 cSt)
Operating Temperatures	-40° F to 180° F (-40°C to 82°C)
Flange Characteristics	Engine Dependent
Pinion Characteristics	Engine Dependent
Weight	28 lbs (12.7 kg)

$$\text{Pinion speed} = \text{engine speed} * \frac{\text{ring gear tooth count}}{\text{pinion tooth count}}$$

$$\text{Engine torque} = \text{starter torque} * \frac{\text{ring gear tooth count}}{\text{pinion tooth count}}$$

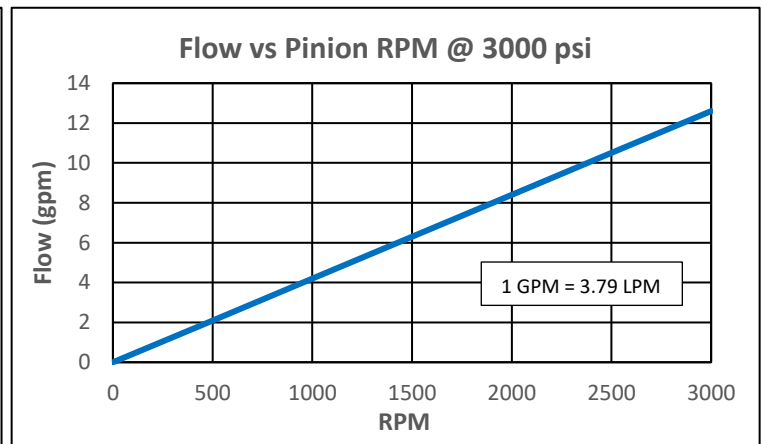
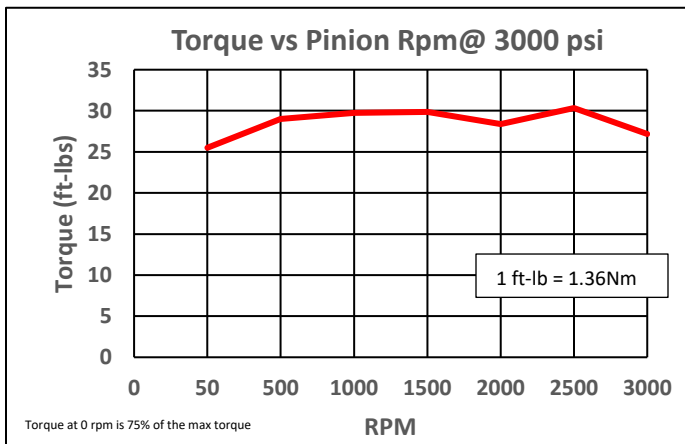

Note: Fitting installation torque:
Follow fitting mfg. recommendations

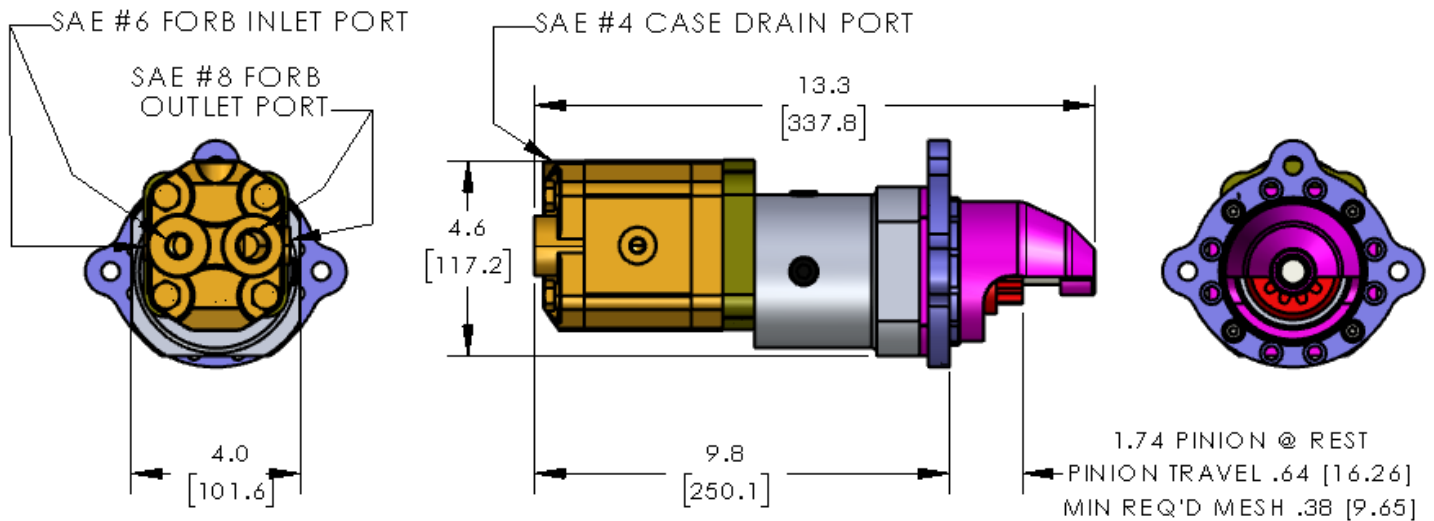

Note: Case Drain must be vented to the tank or return line

Units: in [mm]